

Information Data – Technical Description of
Existing Building Automation and Control Systems (BACS)
in Metro Lines 2 and 3

Table of contents

1. Technical Description of the System SICLIMAT X (SIEMENS) in the nineteen (19) stations of the Base Project (Line 2 : Sepolia – Dafni and Line 3 : Ethniki Amyna – Monastiraki)

2. Technical Description of the System EBI (HONEYWELL) in the seventeen (17) stations of the Metro Extensions (Phases A' and B')

**Technical Description of the System SICLIMAT X
(SIEMENS)
in the nineteen (19) stations of the Base Project
(Line 2 : Sepolia – Dafni and
Line 3 : Ethniki Amyna – Monastiraki)**

ENVIRONMENTAL CONTROL SYSTEM

WITH

BUILDING CONTROL SYSTEM SICLIMAT X (OF SIEMENS)

PRESENTLY INSTALLED IN

ATTIKO METRO

SYSTEM DESCRIPTION

APPENDIX A: ENVIRONMENTAL CONTROL SYSTEM WITH BUILDING CONTROL SYSTEM SICLIMAT X

For the computerised monitoring and control of the Environmental Control System (ECS) within the ATTIKO METRO Base Project stations and tunnels, the SICLIMAT X system has been installed by SIEMENS. It comprises of centrally located equipment in Syntagma station Central Control Room and local equipment throughout the metro network, monitoring and controlling all the main system fans and other related HVAC equipment. A system description is given in the following sections.

A1 GENERAL SYSTEM DESCRIPTION

Building Control (Building Automation) using the system SICLIMAT X relies on monitoring, optimisation and control (open- and closed-loop control, DDC), instruments and devices for the automatic realisation of functional sequences on the basis of pre-set parameters, thereby not only reducing the workload of the operator but yielding better results through the elimination of human errors.

A1.1 Intelligent Building Management

The ECS for ATTIKO METRO (see also attached figures), exploits all possibilities for rationalisation, reduction of energy consumption, optimally safe operation and reduction of maintenance requirements.

This concept for ECS is based on the principle of distributed intelligence i.e. automation tasks are handled at the place of their occurrence, whereas functions associated with controlling, monitoring and optimisation of individual technical systems are handled on the automation and process level. This process of "task displacement" from the control centre to local systems has been possible by the application of modern microelectronics, namely DDC technology, with programmable controllers (PLC) at the automation level and with control centres and higher level tasks being processed at the operations management level. DDC technology enables high precision control and calculation. However, due to the often harsh conditions at the location of use, robust instrument technology with a high degree of precision is required. The system has been specially tailored to these requirements, using standard industrial components throughout which have been designed for use in process and production automation and have been proven in all branches of industry.

Furthermore, the programmable controllers (PLC's) are based on well-proven industrial standards. This ECS is based on various ranges of programmable controllers with different performance characteristics. They have a modular design, i.e. they can be matched flexibly and cost-effectively to all kinds of different, even expanding tasks (upward compatibility). Programmable controllers are linked to a building control system via a bus system with a standardised interface. In addition, several programmable controllers can be linked by means of a bus system to exchange information independently of the control centre (peer-to-peer communication).

A comprehensive range of standardised, freely combinable software-function-blocks is available for the programmable controllers for solving building automation tasks.

Another important factor in the field of Building Management/- Automation is the operation and monitoring concept which should be as simple and straightforward as possible while, at the same time, largely preventing faulty operations. The operation

and monitoring concept fulfils these requirements through a clear-cut operating hierarchy with multiple-level operator information and operator guidance through prompting menus.

There are three task-oriented levels:

- Central Control-Level (Operations Management Level)
- Automation-Level
- Field-Level

The automation in the field-level plus an automation station or groups of automation stations acting as an "automation-island" is capable of communication and enables autonomous handling of tasks. For each "automation island" several central units may act together forming a system (X-OS = operator station/basic system; AS = automation station).

In spite of this complexity, this ECS provides a homogenous, easy-to-handle operator environment.

A1.2 Open Communication

Modern automation concepts require open, future-oriented communication systems, allowing communication between instrument families of various different manufacturers. Computer performance and memory can be adapted to expanding demands through the application of international standards at the control level, such as UNIX System V, X-Windows and OSF/Motif, TCP/IP-protocol.

A1.3 Top Down/Bottom Up

The application software is loaded down into the Central Processing Unit (CPU) of the main S5-automation stations (SIMATIC AS 135 PLC's) via the system bus (Downloading). Changed parameters, control values, warning and fault limits can be loaded back up into the X-OS unit again (Up-loading).

A1.4 Application Software

Standardised function blocks and a clearly defined interface are a vital prerequisite for consistent operation and monitoring as well as consistent engineering. These function blocks can be executed as technologically autonomous typically on a CPU of an automation station.

A1.5 Operations management level

The main features of the ECS are detailed as follows:

- HVAC equipment associated with maintaining the correct environmental conditions of the building complex are controlled by the ECS
- The system runs automatically with minimum personnel (operator) interaction.
- From various levels and locations around the building complex, authorised personnel have the ability to control and change environmental conditions

- A full graphic workstation (X-Terminal) enables the system operators to easily and effectively monitor the functional operation of the HVAC equipment.
- Analysis of faults, trends and equipment operation is rapidly undertaken by the ECS.
- Distributed Intelligent Controllers, with the ability to register and communicate to the central control centres via bus networks, enable optimisation of operation with minimisation of cabling.
- High performance, industrial standard (SIMATIC S5) automation stations are used for the data processing, measurement, control and monitoring of information.
- All information connected to the PLC of each station (app. 300 digital and analogue I/O points per station) can be controlled and monitored from the dedicated X-Terminal in the OCC. For example, the ECS will give to the operator the status of each individual fire damper, filter or fan. This enables the OCC operator to give the precise detailed information directly to the maintenance staff.
- From the ECS not only the main supply and exhaust fans can be controlled, but all other devices as e.g. exhaust fans of electrical rooms and staff rooms, chillers and pumps of each station can also be controlled by the operator. The individual status, alarm or fault of each fan is monitored at the ECS console.
- Through time-/event-switching programs running on the ECS various scenarios and combinations of device actions can be easily created and modified by the ECS system operator, to optimise the requirements of the station and tunnel ventilation system.

A2 LOCAL CONTROL AND AUTOMATION-LEVEL

To capture the data points from around the whole system, subunits (e.g. SIMATIC ET200 distributed I/O system) are used, with a connection to the Automation Stations (AS). Depending on the incoming data (digital and analogue inputs) some controls are executed automatically by the automation units e.g. to activate units (for example fans/pumps/valves).

The automation level equipment is made up of the following sub-systems:

- Automation Stations - SIMATIC-AS 135 /AS 95U
- Electronic Terminators (SIMATIC-ET200 distributed I/O system)
- Communications bus system

A2.1 Automation Stations

High performance, industrial standard (SIMATIC PLC) automation stations are used for the data acquisition, control and monitoring of information obtained from the automation/process-level.

The Automation Stations are single or multiprocessor device, allowing distribution of processing tasks between CPUs. It is modular in design thus enabling the appropriate hardware modules to be selected according to the task.

The communication between the Automation Stations and the X-OS is realised via the 'process bus' using the SINEC L2 bus system. The system enables peer-to-peer communication not only between the two automation stations but also between automation devices configured subordinately to them.

Decentralised equipment can be used within the single automation system using electronic terminator subsystems (see below).

Other local automation systems can be connected with the automation systems on the process bus using a local process bus (SINEC-L2).

A2.2 Distributed I/O System SIMATIC-ET200

Electronic terminators are used for control of decentralised equipment with limited I/O requirements & thus allowing the amount of connecting cabling to be minimised. The electronic terminator units communicate via the L2 bus with the Automation Stations.

A3 CENTRAL CONTROL LEVEL (OPERATIONS MANAGEMENT LEVEL)

From the OCC, it is possible to interface with the Automation Stations, communication being undertaken via the L2 bus system.

It is possible to control from this central position the environmental control devices of entire station and tunnel complexes.

The Central Control equipment consists of X-Terminal operator units, these being 19" monitor user interfaces, with state-of-the-art graphics capabilities.

A terminal bus system connects the X-Terminals to the system Operator Stations (X-OS) PCs. A set of Operator Stations (X-OS) PCs is responsible for the overall control & functionality of the complete system, with information received from the external locations distributed between them.

A3.1 X-OS - Operator Station

The Operations Control Centre has a different number of Operator Station PCs. Each PC is equipped as follows:

- Processor INTEL Pentium II with 266MHz,
- Operating system SCO UNIX 5.0.2; Release 3.2 System 5 - 128 Mbytes Main Memory
- P-Cache 2*8 kB, S-Cache 256 kB
- Hard disk 4 Gbyte
- Floppy drive 3.5"
- 14" system monitor (VGA) + keyboard 1
- parallel + 2 serial interfaces
- Ethernet Interface Card for terminal bus
- Terminal bus, Terminal bus connection module and Terminator Ethernet 10 base 2
- Interface Card (SINEC L2) for process bus
- Uninterruptible Power Supply UPS 0,7 kVa

- 4Gbyte DAT-Streamer (digital audio tape) is used for archiving system- and user-data.
- Ethernet Printer Port, 2 serial & 2 parallel.

A3.2 X-Terminal

NCD 19" X-Terminals are connected to the terminal bus network (Ethernet) from which the authorised system operator is able to access information throughout the entire system.

Further X-Terminals may be added to the terminal bus (up to a total of 4 per X-OS) should expansion of the system be required.

The X-Terminal is a full graphic colour user interface with a NCD 19" colour monitor, keyboard, mouse & printer interface.

Screen definition	:	1280 x 1024, 256 Colours, 70 Hz non interlaced
Processor	:	88100 RISC
Memory	:	24 Mbytes

By using the X-Terminal it is possible to configure, (modify and adjust the parameters), control and regulate the automation equipment, independent from the other control level, via bus systems and to monitor the operation of the electrical, air-conditioning and environmental control devices in the system.

A3.3 Printer

The following printers can be used within the system:

- Line Printer
Line Printers are used for the routine printout of incoming events & alarms, messages and reports.
- Colour Printer
Colour Printers are used for the printout of pictures and trends.
- Laser Printer
Laser Printers are used for the printout of Engineering Manager Function diagrams and for the printout of pictures and trends.

A4 BUS SYSTEMS

A4.1 Terminal Bus

The Operations Control Centre has a local area network bus system used to enable the user interface devices (X-Terminals, Printers) to communicate with the X-OS operator stations.

The system used is an Ethernet Bus with the physical possibilities thin Ethernet, SINEC H1 Ethernet or.

A4.2 System Bus

The bus system used for the System Bus is the SINEC L2 - STF (Technological Functions profile).

Via this bus system, the connection between the Central Control Centre (X-OS operator stations), the automation stations AS and the electronic terminators ET 200 is made.

- SINEC L2 - STF Bus

This bus system has the following technical specifications:

- PROFIBUS Specification (of DIN V 19245)
- Transmission rate 9.6k to 1.5 Mbit/s
- Communication protocols : RS485 or FSK modem

For each physical connection to the bus cable a bus coupling unit RS485 is used.

A5 SYSTEM STRUCTURE

A5.1 Operations Management Level

The operations management level comprises of 2 X-OS, each provided with 2 SINEC-L2 system busses. Each bus is connected to a FSK-Modem (Baudrate 19,2 kBaud). This allows the extension of the logical bus length (necessary for the long distances between X-OS and automation stations AS 135 in the stations).

Two X-Terminals are connected to the X-OS-system via the terminal bus. Each X-Terminal allows to analyse and operate all automation PLC's. Messages can be divided between the two X-Terminals (for example Line 2 on X-Terminal 1, Line 3 on X-Terminal 2).

4 Printers are connected to the system as follows: two line printers, one to print out the event-orientated information (status changes, faults, alarms) of Line 2; the second one for the event-orientated information of Line 3. The third one is a colour printer to print out trends and system pictures. The fourth one is a laser printer for documentation of software engineering and (fast) black/white system pictures.

A5.2 Automation Level

Currently, there are 12 Automation Stations SIMATIC AS 135 used for the control of Line 2. 9 automation stations SIMATIC AS 135 are used for the control of Line 3. Each one of the Automation Stations is located in switchboard SBS3.1 of the Stations.

Each Automation Station is provided with a CPU922 and two Communication Processors. One of the communication processors is responsible for the communication with the X-OS (process bus). At the same time communication to the two nearest AS 135 (of Station -1 and station +1) is given, even if the X-OS is not running.

Exception: the stations at the end of each line; there is only one "near" station.

The other communication processor is used for communication to the intershafts (local process bus). Each AS 135 is connected to the dedicated shaft PLC (SIMATIC AS 95U).

All bus connections are realised with FSK-Modems to enlarge the logical bus length (necessary for the long distances between AS 135 of the stations and automation stations AS 95U in the shafts).

Each AS 135 is connected to the Fireman-Box and the Station Master Panel using two SIMATIC ET200U to monitor and control the system depending upon the signals of the Fireman-Box/Station Master Panel.

A6 TECHNICAL ON-LINE ASSISTANCE

Through a modem integrated in the workstations and an ISDN line, an on-line service and technical support from the SICLIMAT Hot-Line situated in the SIEMENS offices in Karlsruhe/Germany is possible. This reduces break down time, and enables easy support of the operating staff, software maintenance and software upgrading of the system.

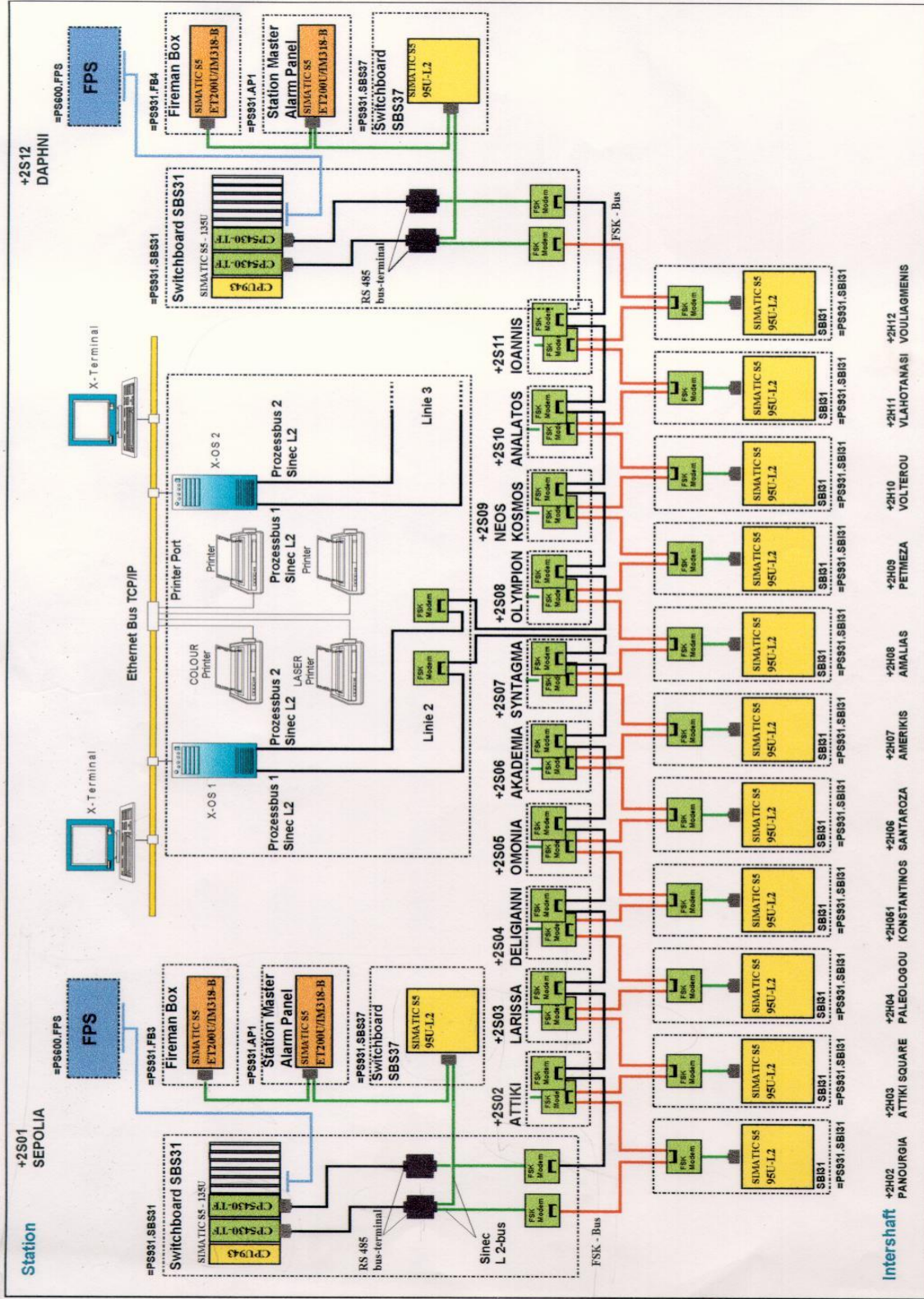

Rev.	Remarks	Date	Name	Norm
		20.06.1997	Wichers	
			Appr.	
			Puultsch	

Date		20.06.1997	
Drawn		Wichers	
Appr.		Puultsch	
Date			
Name			
Norm			

OLYMPIC METRO ATHENS	
VENTILATION SYSTEM ARCHITECTURE - LINE 2	
2G00PS900G001 Rev.A	
Sh. No. 1	Shs

Intershaft

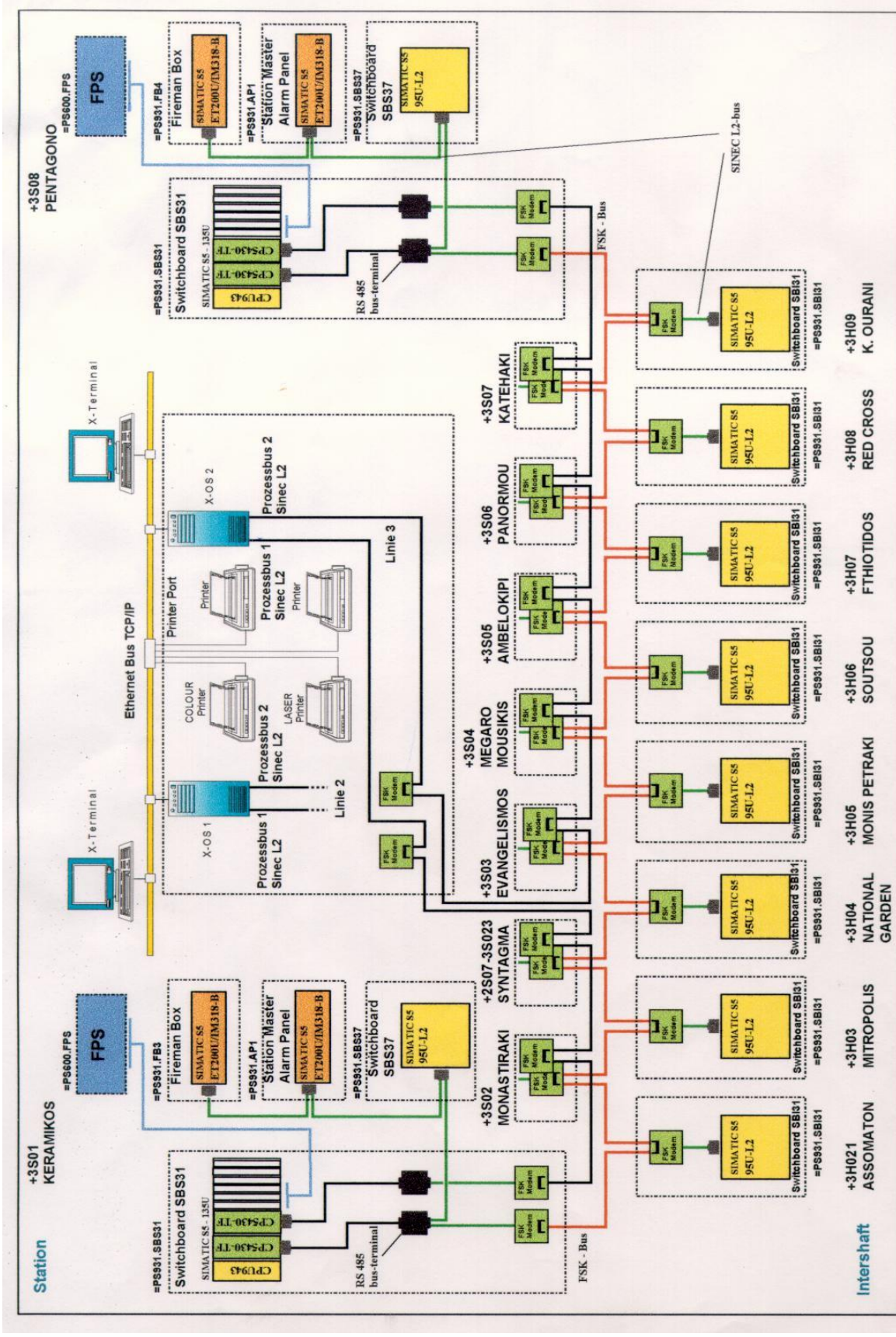

Station	Station	Station	Station	Station	Station	Station	Station	Station	Station	Station	Station											
+3S01 KERAMIKOS	+3S02 MONASTIRAKI	+3S03 MITROPOLIS	+3S04 NATIONAL GARDEN	+3S05 MONIS PETRAKI	+3S06 SOUTSOU	+3S07 FTHIOTIDOS	+3S08 RED CROSS	+3S09 K. OURANI	+3S10 KATEHAKI	+3S11 PANORMOU	+3S12 MEGARO MOUSIKIS	+3S13 AMBELOKIPI	+3S14 EVANGELISMOS	+3S15 MEGARON MOUSIKIS	+3S16 SYNTAGMA	+3S17 MONASTIRAKI	+3S18 SYNTAGMA	+3S19 EVANGELISMOS	+3S20 MEGARON MOUSIKIS	+3S21 AMBELOKIPI	+3S22 PANORMOU	+3S23 KATEHAKI

Rev.	Remarks	Date	Name	Norm
		20.06.1997	Wichers	Pauflitsch

Intershaft

VENTILATION SYSTEM
ARCHITECTURE - LINE 3

**Technical Description of the System EBI
(HONEYWELL)
in the seventeen (17) stations of the Metro
Extensions
(Phases A' and B')**

Contents

1.	INTRODUCTION	82
2.	OBJECTIVES OF THE PROJECT	82
3.	SYSTEM ARCHITECTURE / TECHNICAL DESCRIPTION	82
3.1	General Architecture.....	82
3.2	Station Architecture	82
3.3	Station Communications Network	83
3.4	Description of Communication Protocol	83
3.5	Station Monitoring System (EBI R410.2)	83
3.6	HC900 controller network	88
3.7	Station interconnection	89
3.7.1	Network architecture.....	89
3.7.2	Communication between HC900 controllers at different stations	89
3.8	Fireman Box	91
3.9	Priority of Scenario Selection and Execution	91
4.	INTERFACING THE LOCAL EQUIPMENT WITH SYNTAGMA OCC AND THE LOCAL MONITORING SYSTEM	92
4.1	Interface between Syntagma EBI Server and HC900 in Stations.....	92
4.2	Interface between Syntagma EBI Server and local EBI station/server	94
5.	INTERFACE BETWEEN LOCAL EQUIPMENT IN THE NEW STATIONS AND THE EQUIPMENT IN THE STATION OF PHASE A' EXTENSIONS .	94
6.	SYSTEM REDUNDANCY CAPABILITIES	96
6.1	Monitoring Malfunctions (EBI).....	96
6.2	Communications network Malfunctions.....	96
6.3	Extreme cases of Malfunctions	97
7.	COMPLIANCE WITH THE SAFETY INTEGRITY LEVEL SIL-2.....	97
7.1	Replacement of the two EBI station with one EBI Server.....	97
7.2	Changing the structure of the Ethernet network.....	98

1. INTRODUCTION

This document aims at describing the Building Automation and Control System (BACS) that Honeywell intends to install in the new extensions of the Athens Metro.

2. OBJECTIVES OF THE PROJECT

The scope of the project is the monitoring and control of the tunnel ventilation system, the HVAC system and of the building electromechanical systems locally from the workstation at the Station Master Room and centrally from the existing operating Honeywell EBI workstations in SYNTAGMA Operations Control Centre (OCC).

The design and all necessary works for the Fireman Boxes and the PLC panels are interrelated with the present design. The BACS system shall comply with the Safety Integrity Level SIL-2, as per the current European Standards.

3. SYSTEM ARCHITECTURE / TECHNICAL DESCRIPTION

3.1 General Architecture

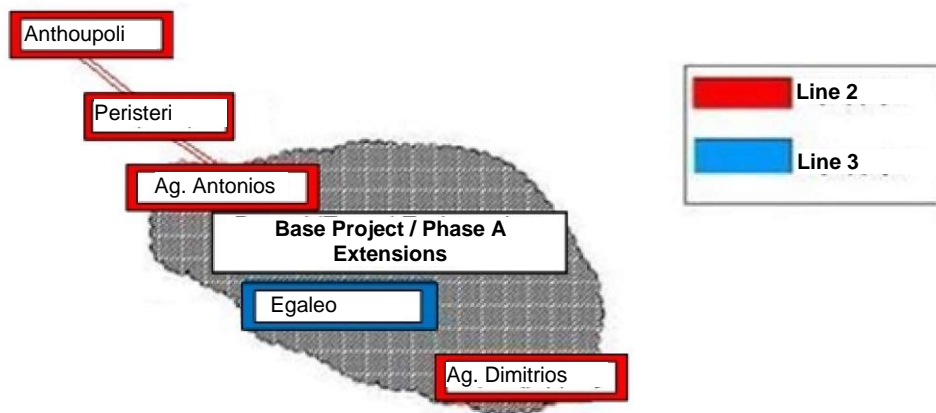

3.2

Station Architecture

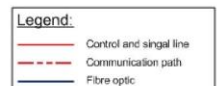
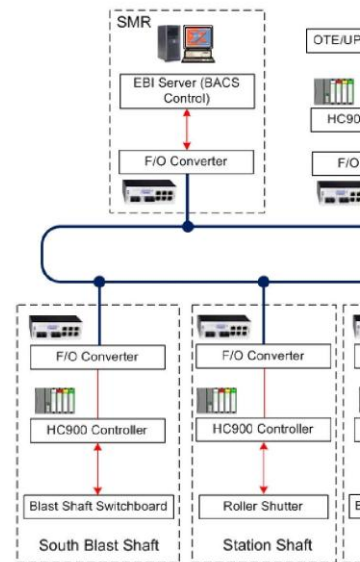

3.3 Station Communications Network

An autonomous fibre-optic network shall be configured in the Station. The network shall be of a ring topology, as shown on the diagram, where each of the two fibre optic paths follows different routing. Thus, if one of the two optic cables fails, communication is not affected. The utilization of monitored and programmable F.O. Switches enables control in case optic connection is broken at ring closure points. Connections between the FO Switches and operating equipment (HC900, EBI Sever, OTN) shall be implemented via a UTP cable. The Local Area Network (LAN) configured inside the station communicates with the Wide Area Network (WAN) of the Metro system via connection to the OTN network. The equipment utilized in the building of the this network shall enable data transmission at speeds higher than 100Mbps.

The diagram presented above is a block diagram. For more information, please refer to the System Architecture Drawings – 2GW0PS250O601.

3.4 Description of Communication Protocol

See document 2GW0PS250O600A_Annex B DESCRIPTION OF COMMUNICATION NETWORK.doc.

3.5 Station Monitoring System (EBI R410.2)

The monitoring system to be installed in the Station Master Room of all stations is EBI R410.2 manufactured by Honeywell. The connection of the EBI Server with the station's LAN network shall be implemented via a Fiber Optic Switch serving exclusively the specific area.

The Server to be installed in each station is Dell Poweredge T310 with a RAID 5 layout.

The central computer of the station shall function both as a Server for data collection and processing and as a workstation. All software processes related to database updating, communication with field controllers (HC900) and with the central monitoring system in SYNTAGMA shall not be visible to the user and shall not affect monitoring of the systems (the background processes)-Server processes.

Honeywell Universal Modbus interface (for HC900 controllers) Communication Protocol shall be part of the EBI Server software, an interface developed to achieve full communication between the HC900 data tables and the EBI Server database. All information and functions available by means of direct local connection to the controller (input status, output activation, outputs status, feed-back on HC900 status, status of all programmable false-points) are transferred to the EBI Server database.

Pieces of equipment shall be grouped so as to minimize delays during operation and the screen shall display the following of links to navigate to other pages:

- Overview of the station's schematic, providing the user with access to lower system levels
- Schematic diagrams of various systems
- Schematic diagrams of equipment
- Display of alarms and alarm summaries in a tabulated form
- Display of status or event messages in a tabulated form

- Display of sensors values in a tabulated form
- Display of all relevant scenarios per station
- Display of the status of all emergency scenarios
- Mimic display of the FB
- Fire alarms and fire dampers status
- Trends and history data.

Other features shall include the automatic navigation to the alarm source after detection, zoom in/zoom out, scroll up/down.

The EBI server shall provide, among other information, the following:

- Supervision and operation of active equipment via graphic screens (masks)
- Overall supervision of communication channels and controllers
- Grouping of multiple points/false points
- Development and use of schedules
- Monitoring of analogue values via a graphic diagram (trend)
- Complete alarm list with alarm categorization by order of priority
- Event list showing every task executed from the EBI server and the connected workstations, as well as any change of status at control points
- Automatic event archiving
- Users with distinct authorization levels, with the option to assign multiple authorization levels to each user.

The BACS operator shall have the possibility to execute all monitoring and supervisory functions from the this workstation. The standard commands issued by the user shall include: modification of the control loop setpoints, response to alarm and customization of the setpoints, automatic / manual switchover and of on/off control of the field devices and activation / deactivation of setpoints and devices.

The operator in the OCC shall have access to all names of variables or graphic displays of the Tunnel Ventilation system and the Heating, Ventilation, Air Conditioning (HVAC) system in stations and E/M systems in stations and tunnels of the network, without knowing which server, or data logger, or PLC is the source of the variable or the graphic display. Moreover, the operator shall be updated about the status of an alarm via an audible signal, a displayed message, or any combination of animations on the screen.

The user shall be able to select and identify the alarms individually, per group, or process type. Moreover, the user shall be able to identify only the alarms displayed on the screen, have been are selected only during the most recent alarms, or during the system alarms. In addition, the user can select an alarm from the alarm summary table and the system shall switch to the corresponding screen.

The BACS software shall support the simultaneous user access to multiple screens, including the split screens, where the user can project each time more than one fields of the process.

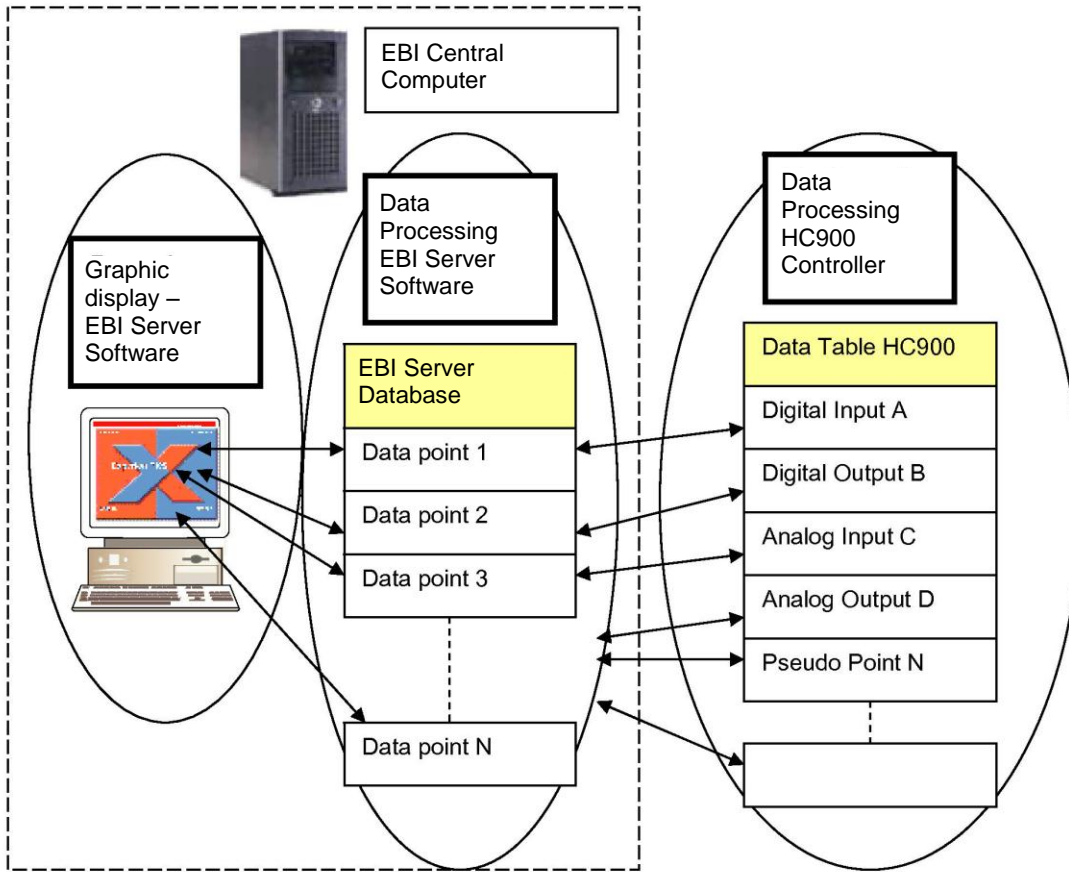





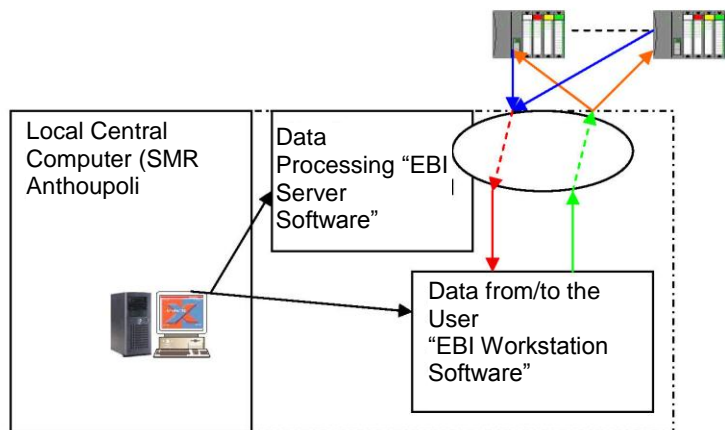

The workstation shall be capable of communicating with both Metro network EBI Servers (at SYNTAGMA and in the station) which collect information and control the equipment of the local station. More specifically:

- The workstation shall serve as workstation of the station EBI Server, while data flow shall be local, within the LAN. For example, when the user activates a fan from the graphic screen, this command shall be transmitted to the local EBI Server software, which shall act accordingly to transmit the command to the HC900 controllers. Similarly, the local EBI Server software shall be the source of the data for graphic screen update and user warning about the effect of his action.

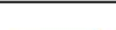
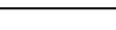

Legend

	Command to field		HC900
	Signal from field		Central Computer EBI Server/Station
	Command processing		
	Signal Processing		
	Data to HC900		
	Data from HC900		

- it shall operate as Redundant Syntagma EBI Server workstation and data flow shall be implemented via WAN.

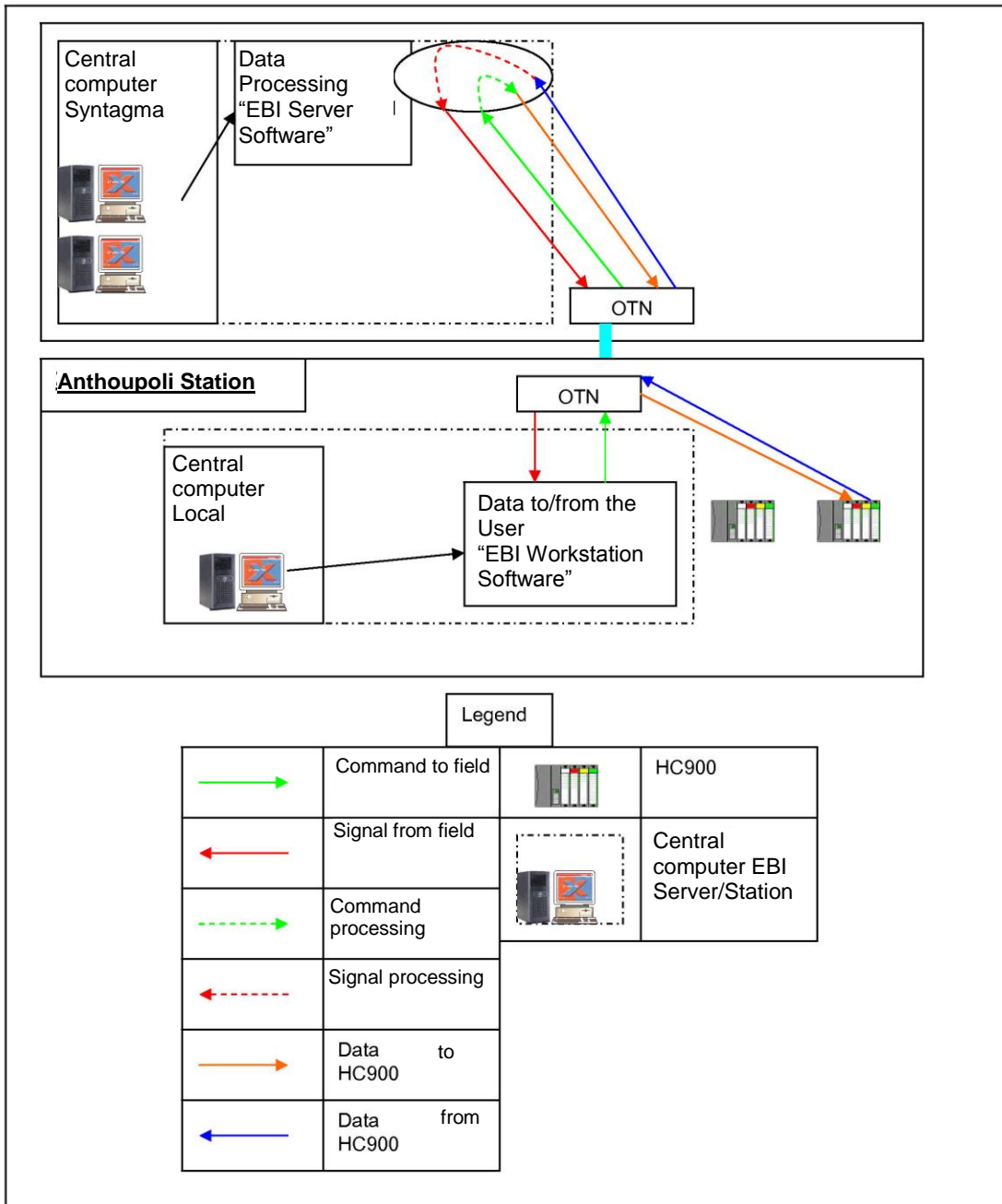

For example, when the user activates a fan from the graphic screen, the relevant command shall be transmitted via WAN to the Syntagma EBI Server, wherefrom the appropriate actions shall be implemented to transmit the command to the HC 900 controllers of the station. Similarly, the Syntagma EBI Server shall be the source of the data for graphic screen update and user warning about the effect of his action.

3.6 HC900 controller network

The HC900 control level is independent and operates separately from the EBI monitoring level. All information necessary for the execution of the algorithms are exchanged among HC900 controllers via PEER-to-PEER communication. All HC900 controllers of the station operate as master controllers and exchange information directly with the monitoring level – they do not operate on a “master/slave” configuration.

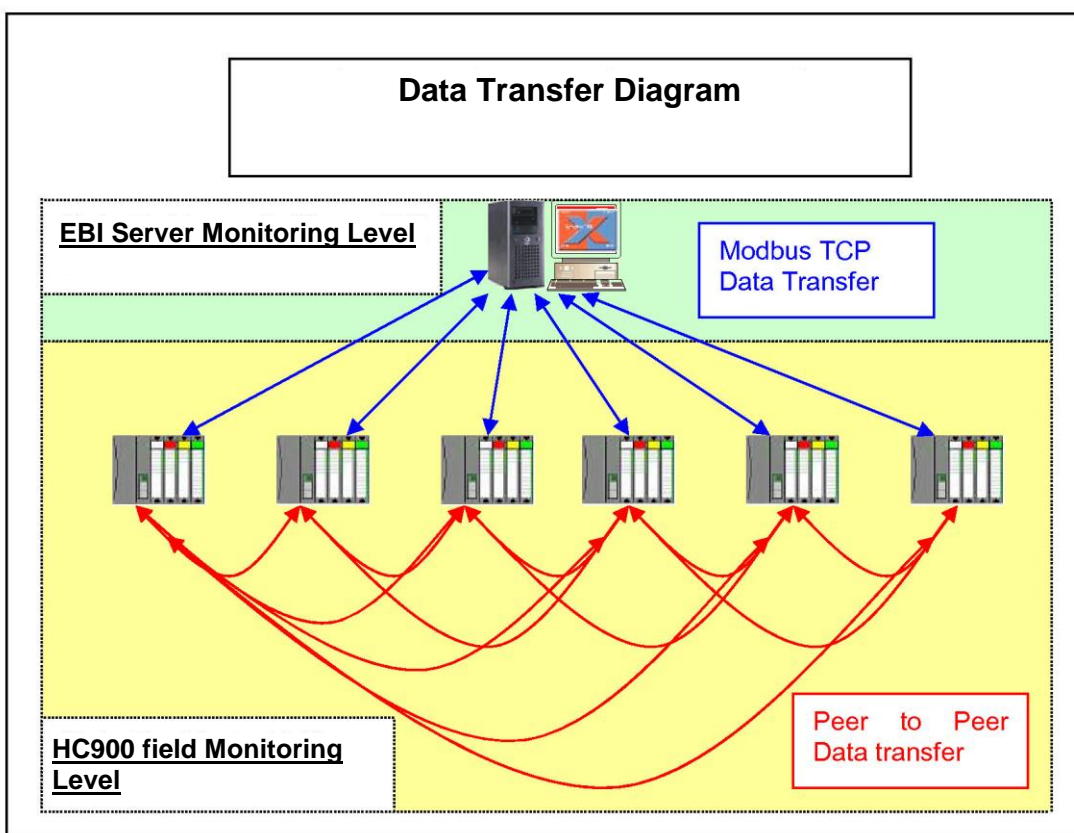

The above diagram presents the data transfer method in the system. The HC900 controllers communicate with each other via PEER-to-PEER communication, irrespective of their physical location on the network (as shown in the above diagram for the first HC900 controller). All controller directly transmit data, irrespective of their physical location in the network, to the EBI Server of the Station via the Modbus TCP protocol.

3.7 Station interconnection

3.7.1 Network architecture

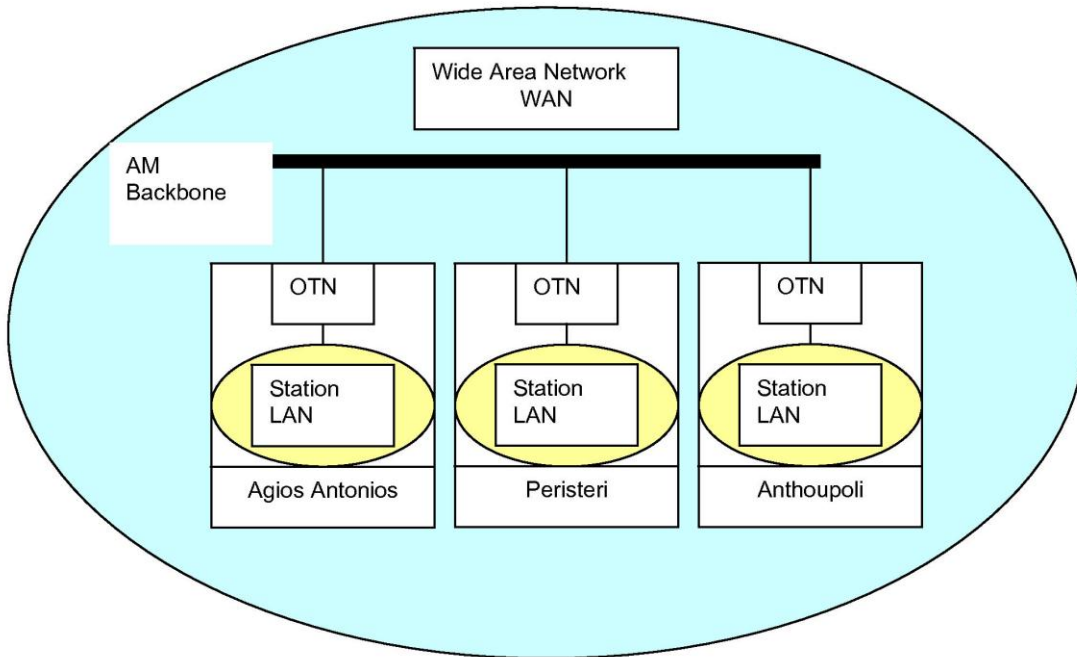

The local LAN networks of the stations communicate with each other via the Metro WAN network. The link between LAN and WAN is implemented via the OTN.

As regards the BACS system, this is necessary for the data exchange between:

- HC900 controllers of the adjacent stations
- HC900 controllers and the EBI Server in OCC
- The EBI Servers of each new station and the EBI Server in OCC

3.7.2 Communication between HC900 controllers at different stations

The station HC900 controllers must necessarily communicate with each other, in order to achieve field control independence. Thus, the activation, for example, of a fire scenario from the graphic screen in the Fireman Box in station N shall be successfully implemented irrespective of the status (ON or OFF) of the EBI servers of the remaining system, because the option is provided to activate the equipment in the adjacent stations.

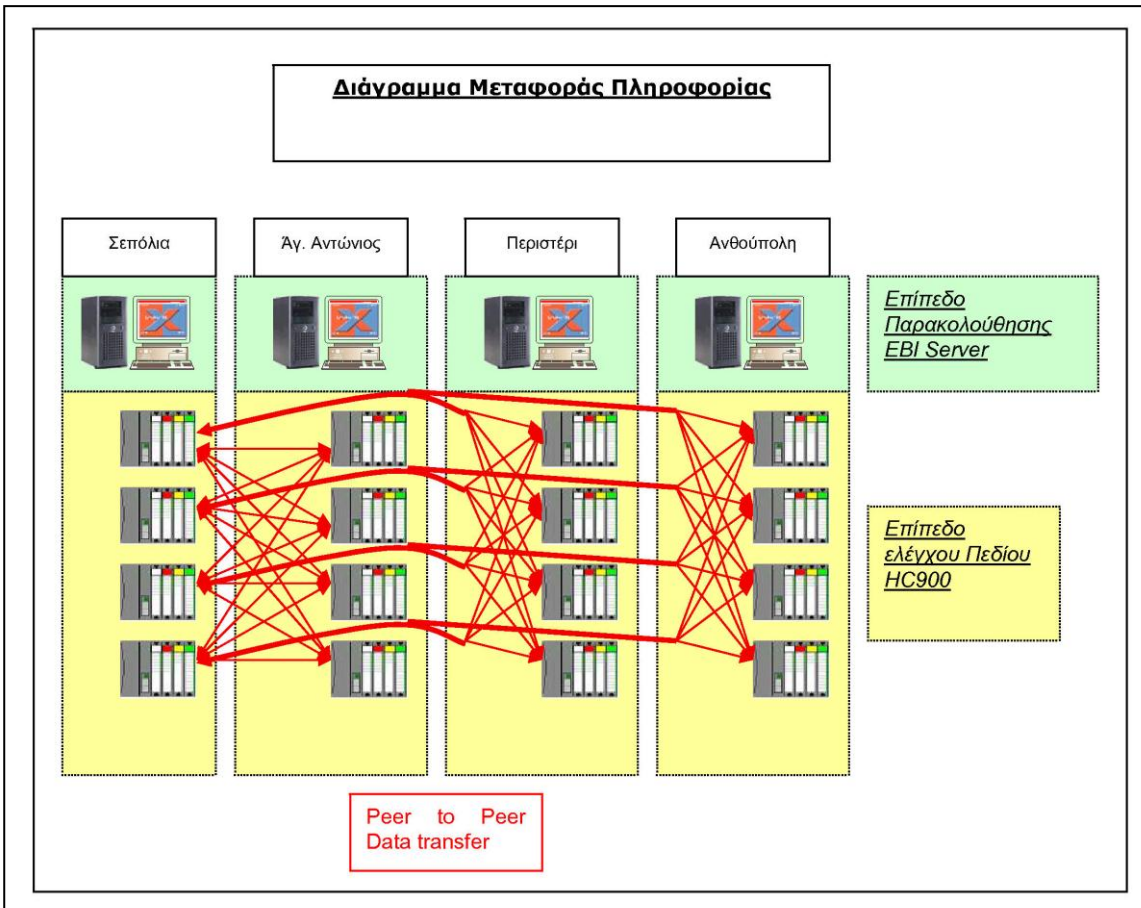

HC900 controllers communicate via the Modbus on a Peer-to-Peer basis. This type of connection makes feasible the display of necessary information about the equipment of adjacent stations on the local EBI Server, for example the display of the entire line to confirm the proper implementation of a scenario involving this specific station. Thus, and as shown on the above Figure, each HC900 controller communicates with the other controllers and implements the respective actions, when necessary. For example, when activating a fire scenario which involves multiple HC900s in various stations at the same time, the Peer-to-Peer communication provides the possibility to select a scenario at one controller and implement the actions towards the controllers of the local station and the neighboring stations (UPE, Blast Shaft, RS etc.) as required by each scenario.

3.8 Fireman Box

The Fireman Box system is made of the following components:

- The fascia, which houses the Mode Switch (Remote Operation Scenarios) and instructions for scenario selection and operation.
- Selection buttons for two scenarios (FIRE ON THE PLATFORM, FIRE ON THE CONCOURSE), for activating the scenarios and the transmission of simple wired commands:
 1. to the mimic panel SWB-BSF of the east shaft, which supplies with power fans BSF1, BSF2
 2. to the mimic panel SWB-BSF of the west shaft, which supplies with power fans BSF1, BSF2
 3. to the mimic panel of the platform fans SWB-UPE/OTE, which supplies with power fans UPE/OTE1, UPE/OTE2
- Visual indications about the operation mode of the equipment in the station, the west shaft and the east shaft
- Visual indications about the proper operation of the selected fire scenario at the involved equipment located before and after the station
- The required power for the visual indications on the fireman box shall be supplied by the respective SWBs connected to the FB; indication bulbs shall be fed with +24VDC from the SWB-UPE/OTE SWB
- Fireman Box Bulbs control button (No control points required on the FB)

The FB shall not incorporate any processing unit or any other complex logic device

With the view of increasing the system availability in case of failures, the Mode Selection Switch (Remote Operation, Scenarios) and the scenario selection buttons are hard wired to the UPE and BSF SWB of each station. Selection and implementation of any scenario is executed at the PLC-UPE and the commands shall be transmitted to the respective PLCs. In case of failure of the PLC-UPE, the scenario can be selected and implemented at the PLC-BSF of the west shaft, without requiring any additional actions by the user.

The BACS user shall be transferred to the mimic page of the concerned stations' FB via a link on the central page of the system, or via the station overview screen.

The mimic page of the FB shall provide a graphic display of the following items: Mode Switch status (Remote, Scenarios), all visual indications mentioned above, scenario selection commands and EBI "Scenario – Remote" command. To the right and the left of the station there shall be the FBs of the adjacent stations, showing the respective operation mode indications of their respective equipment. Moreover the indication "FB Active" shall be present, in order to inform the user that the FB of a specific station is activated whenever a specific scenario is executed.

3.9 Priority of Scenario Selection and Execution

The first priority for scenario selection and execution is the Fireman Box. In case of fire, the station master can visit the Fireman Box, set the Mode Switch on the position "Scenarios" and select the scenario to be executed. As soon as the mode switch is returned to the "Remote" position, the execution of the scenario shall be stopped.

The next priority of the equipment operation is the "Local Emergency" changeover switch.

Whenever a scenario is selected by the EBI, any scenario can activate the equipment whose changeover switch is not at "Local-Emergency".

The properly authorized BACS user can go to the page with the FB of the specific station and activate the "Scenario" command, confirm the command and subsequently select the scenario to be execute. Activation of the "Remote" command shall deactivate the "Scenario" command and the scenario shall be stopped.

The start and stop commands by the BACs user, as well as the fan temperature control schedules and algorithms are of a lower priority.

In summary:

- Commands from the local FB prevail over commands from the SMR / OCC, as well as over commands from SWBs whose mode switch is at the "local emergency" position.
- Commands executed from SWBs whose mode selector switch is at the "local emergency" position prevail over the fans' operation selected via scenarios activated from OCC and SMR workstations.
- Commands issued from the emergency screens of the workstation in the SMR prevail over the commands issued by the OCC workstations

4. INTERFACING THE LOCAL EQUIPMENT WITH SYNTAGMA OCC AND THE LOCAL MONITORING SYSTEM

The key points for achieving the full interface between each new station and the OCC are the following:

- a. The central monitoring system at Syntagma
- b. The local monitoring system at each new station
- c. The HC900 controllers to be installed in the new stations

The interface requirements prescribe three types of communication.

1. Communication between the EBI Server (central monitoring system) in Syntagma and the HC900 controllers, to achieve full compatibility.
2. Communication between the EBI Server in Syntagma and the EBI Station (local monitoring system), in order to keep the Powere Controller fully informed about the actions of the local user.
3. Communication between the EBI Server in the Stations and the HC900 controller, for local operation in case communication with EBI Server at Syntagma is lost

4.1 Interface between Syntagma EBI Server and HC900 in Stations

The communication protocol that has been installed in Syntagma EBI Server since Phase A' extensions is **SWEBI-IF-UMC800 Honeywell Universal Modbus** (for the HC900 controller) **interface**.

This protocol permits the full control and monitoring of the HC900 controllers.

Each of the controllers connected to the Metro system WAN network is corresponded to one unique TCP/IP address. Via this address, the controller takes its place in the EBI Server database, enabling the transmission of all parameters (programmable and physical control points), as well as

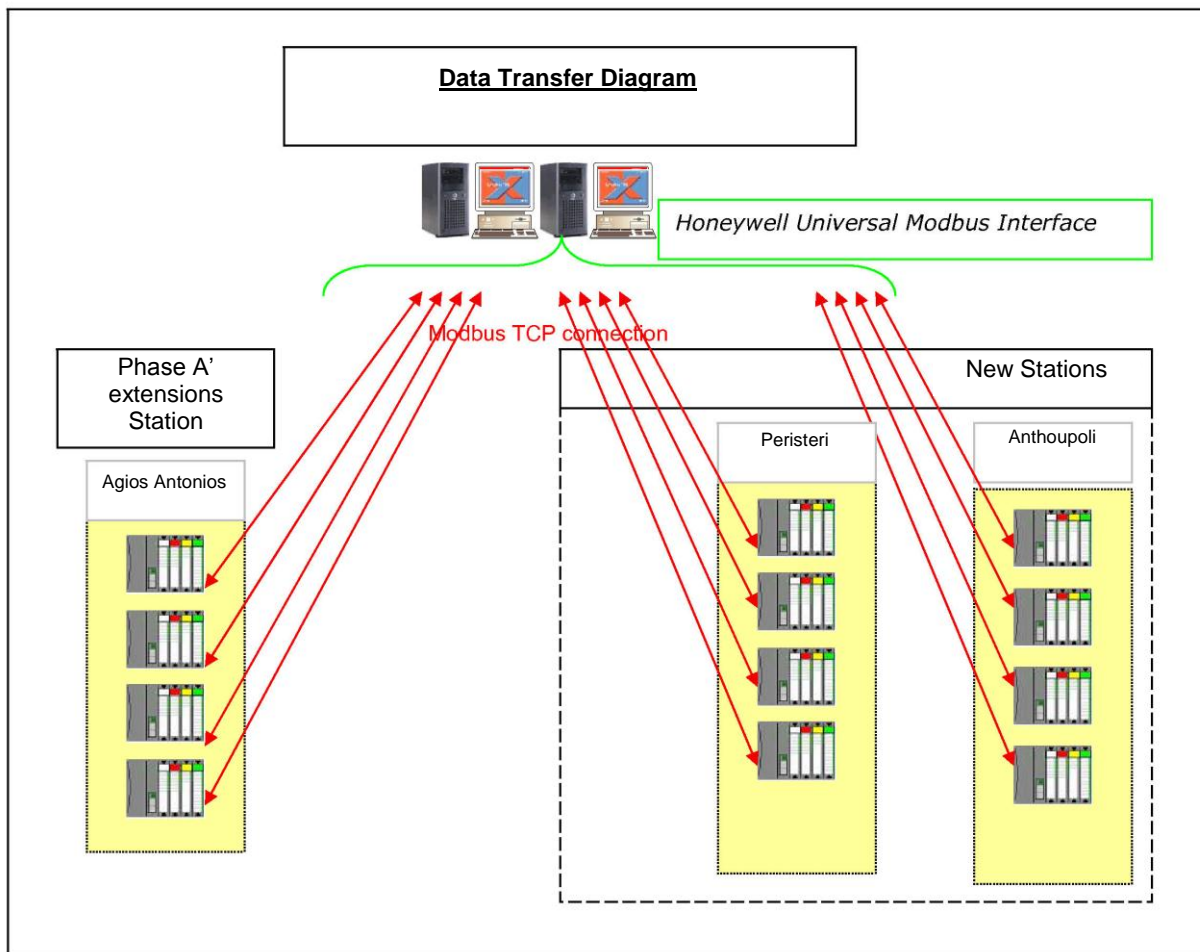

the two-way transmission of all data related to communication problems. The HC900 controllers of the new stations shall be essentially incorporated into the already operating monitoring system (EBI) as an expansion and not as a new addition, and thus nothing shall change for the OCC users as regards the monitoring and control activities for the phase A Metro extensions.

It must be stressed that the Syntagma EBI Server shall operate in the same fashion as the local EBI Servers, the only difference being that all data shall be transmitted via the WAN network (which does not affect data exchange). The Syntagma EBI Server shall operate in parallel to the local EBI Server at Peristeri as two peer systems, while the two systems shall be fully autonomous and independent.

The properly authorized user of an EBI station in the Syntagma EBI Server shall have the options:

- To activate/deactivate equipment, scenarios
- To change the set points
- To monitor the mode of the station equipment

- To define schedules

All the above actions shall be implemented via a graphic interface and the associated info is transmitted via Modbus TCP. Data exchange between Syntagma EBI Server and the local HC900 controllers is independent from the local EBI Server. The data shall be transmitted even if the local EBI Server is down.

4.2 Interface between Syntagma EBI Server and local EBI station/server

As already mentioned, the workstations in all new stations shall be able to communicate with both EBI Servers (Syntagma and Station) and all actions performed by the station master shall be through Syntagma, while the local interface shall be used whenever communication with Syntagma is lost. For reasons of full compatibility between the stations and Syntagma, all installed and operating EBI Servers and stations (seven servers and 17 stations) shall be upgraded to the most recent software version (EBI R410.2).

5. INTERFACE BETWEEN LOCAL EQUIPMENT IN THE NEW STATIONS AND THE EQUIPMENT IN THE STATION OF PHASE A' EXTENSIONS

The proposed architecture can fully achieve the interface between the future local equipment and the local equipment installed in the adjacent operating stations and shafts of Phase A extensions of the Metro. The decision to install the HC900 controllers constitutes the key advantage for this interface. In the stations that need to be interfaced (Agios Antonios), the ventilation system is controlled by Honeywell HC900 controller, identical to those to be installed in the new extensions. Each controller shall be located inside a local panel with IP55 protection, which shall be separate from the equipment's control panel. These controllers have been designed to exchange data on a peer-to-peer communication basis, which has a proven functionality as testified by their operation on the phase A extensions. In essence, this is an expansion of the already installed controllers, with the addition of identical devices. This fact leaves unaltered all characteristics pertaining to the exchange of information and communication among the HC900 controllers. Below follows a schematic diagram on data exchange among HC900 controllers.

Data Transfer Diagram

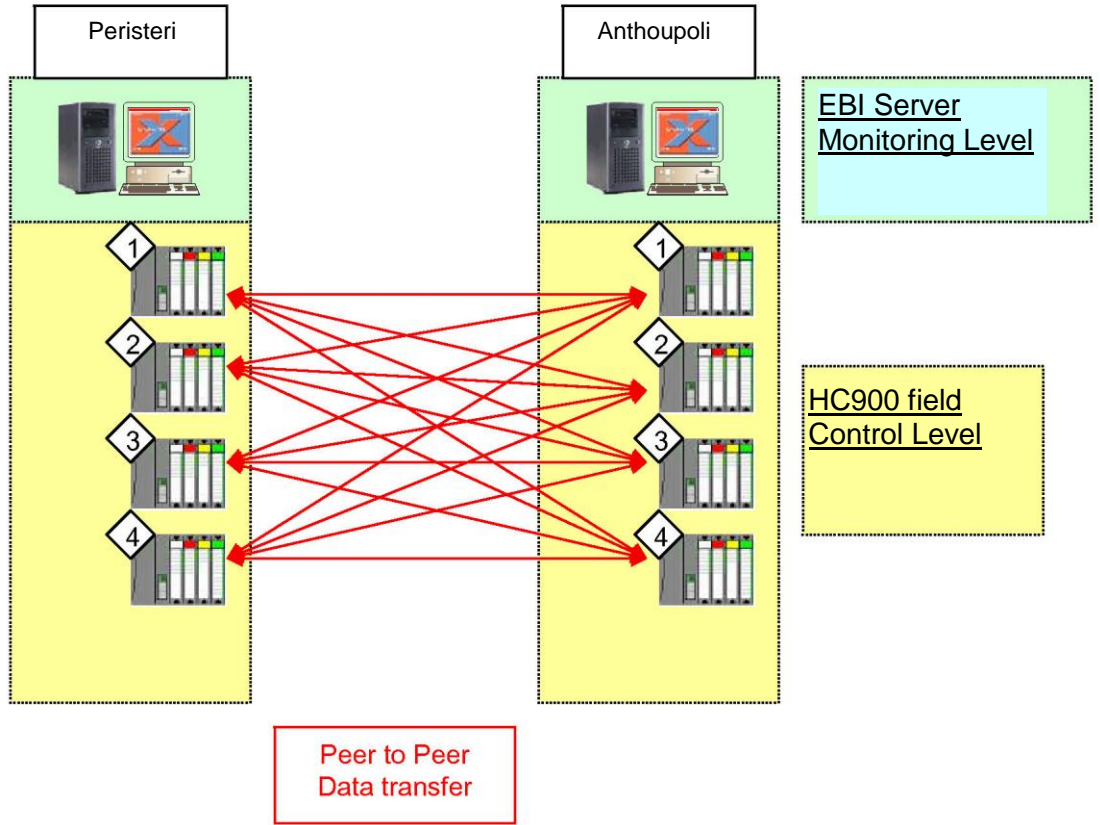

It is worth observing on this diagram that it depicts a network where the phase of the extension to which a station belongs does not play a role, which provides the option for data exchange between Peristeri to Acropoli Station and vice-versa. This is in essence a communication among the HC900 controllers of different stations, as analyzed in paragraph 3.3.2 (precisely the same operation with two adjacent stations belonging to phase A extensions, e.g. Sepolia – Agios Antonios).

It is clarified that wherever Station N is referred to, it is a virtual representation of an area (Shaft or Station, etc.) wherein active equipment is installed. Communication is feasible only via HV900 controllers at any geographical location. In terms of implementation, each controller is assigned a unique code name and a unique TCP/IP address in the entire Metro network (in service stations and new stations). This unique identification data is utilized by any other HC900 controller on the network in order to achieve the link and start data transferring.

Example: assuming that a scenario is activated from the FB in Anthoupoli Station, this information shall be transferred to HC900 controller in Anthoupoli, the scenario shall be activated and the relevant signal shall be transmitted to the proper controllers to activate the pertinent fans, e.g., signal transmitted to the HC900 controller Peristeri 3 (link between Anthoupoli, 1 and Peristeri, 3), as well as to all other required controllers via Peer-to-Peer communication.

6. SYSTEM REDUNDANCY CAPABILITIES

In order to realize the system's response capabilities in case of loss, we shall list the possible problems that may emerge and the how the system responds in each case.

6.1 Monitoring Malfunctions (EBI)

- Both EBI Servers at Syntagma are down

In this case, the EBI Server of the station operated independently to the problem at Syntagma. The user in the SMR fully controls and monitors the local equipment in the station and the shafts (remains connected to the LAN). This user can activate scenarios that can be successfully implemented to the adjacent Stations as well, via a Peer-to-Peer communication of the HC900 controllers.

- Malfunctions to the Station Central Computer

- Failure of the station's central computer's power supply unit
The Station computer continues to function normally since it is equipped with a stand-by power supply unit.
- Failure of the Station's central computer entire hard drive
The Station computer continues to function normally, due to the RAID 5 layout.
- Failure of the EBI Server software
In this case, the user in the SMR shall fully monitor and control the equipment using the EBI station software, which is linked to the Syntagma EBI Server database.
- Failure of CPU, or motherboard, or both power supply units, or both hard drives of the station's Central Computer
In this case, Syntagma EBI Server operates independently to the local Station problem. The user in the OCC shall fully monitor and control the local equipment in the Station and the Shafts. The user can implement the scenarios which shall be successfully executed.

6.2 Communications network Malfunctions

- OTN failure

In this case, the station EBI Server operates independently to the problem at Syntagma. The user in the SMR fully controls and monitors the local equipment in the station and the shafts (remains connected to the LAN).

- Failure of one fiber optic of the LAN network
No problem is generated to the station's communications, due to the ring topology. Therefore, the networks remains operational because of a second path for data transfer is available.
- Loss of power at one FO Switch
No problem is generated to the network, because a second power supply is available

6.3 Extreme cases of Malfunctions

Failure at the control panel of the controllers, loss of an HC900 controller, damaged FO switch:
It is not possible to remotely control the equipment governed by the failed items. However, it shall be possible to control these items locally or through the hard-wired scenarios from the FB, while the remaining system is not affected by the incident. In case a scenario is activated, all involved item shall operate, with the exception of the item outside the network.

7. COMPLIANCE WITH THE SAFETY INTEGRITY LEVEL SIL-2

The system's compliance with the SIL-2 is based on the already operating BACS system of the phase A Metro network extensions, which demonstrably complies with the SIL-2 requirements.

The design for the new extensions preserves the same philosophy for the automation and control systems, with the following differences:

- Replacement of the two EBI station that have been installed on phase A' extensions with one EBI Server.
- The transformation of the LAN network serving the BACS needs from a line network, to a ring network.

Let's examine each of these two changes in terms of system availability.

7.1 Replacement of the two EBI station with one EBI Server

This is a change that increases the system availability, because, in the phase A Stations:

- In case of OTN failure, the station cannot exercise control and monitoring via the software because in order for the EBI station to become operational, it must be linked with the EBI Server Syntagma; moreover, remote control of the equipment is not available. On the other hand, the functions of control, monitoring and remote control are available from the local EBI Server in the new stations.
- In case of failure to the Syntagma EBI Servers, the EBI station becomes inoperative and thus local and remote control and monitoring via software is not available and the scenarios can only be activated from the FB. In the new stations, however, control and monitoring is available from the local EBI Server and the scenarios operate normally.
- The presence of two conventional computers as opposed to one computer with a RAID 5 layout in the new stations, does not translate to reduced availability, because:
 - In both cases the failure of two power supply units shall lead to the loss of local control
 - In both cases the failure of two hard drives shall lead to the loss of local control
 - Failure of one CPU or motherboard is the only point of advantage for the phase A solution, but even in that case the system remain fully available from Syntagma. It must

be stressed here that it is possible to connect a second EBI station, if so required by the RAMS analysis.

7.2 *Changing the structure of the Ethernet network*

In the fiber optics network that serves the BACS system of the phase A extensions, in case of connection drop, only a part of the network remained available (the part connected to the OTN). In the new stations, however, the entire network remains available on account of the existence of an alternative path for data transfer.

It is worth mentioning that the central computer to be installed in the new extension shall also serve as an EBI station of the Syntagma EBI Server, and thus every new station shall be identical to the stations of phase A (a system demonstrably compatible with the SIL-2 criteria), the only disadvantage being the case of failure of the computer's CPU or the motherboard which is overcome by the system's other features which greatly improve the system's overall reliability.